

ELEKTROMEHANIČKI SERVO POGONI

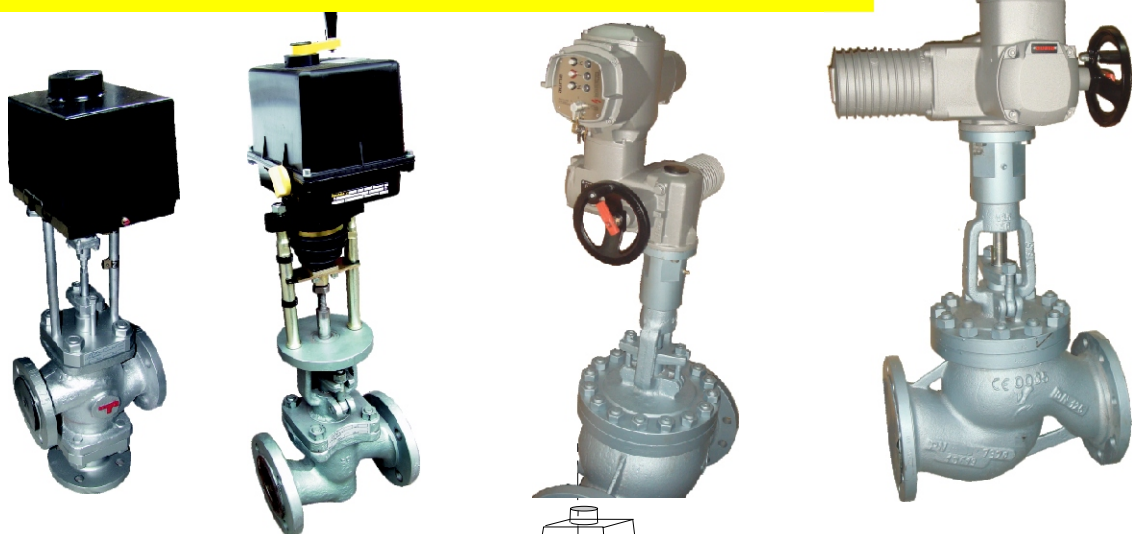

REGULACIONI VENTILI SA ELEKTROMEHANIČKMI SERVO POGONIMA



5

LOKALNE REGULACIJE

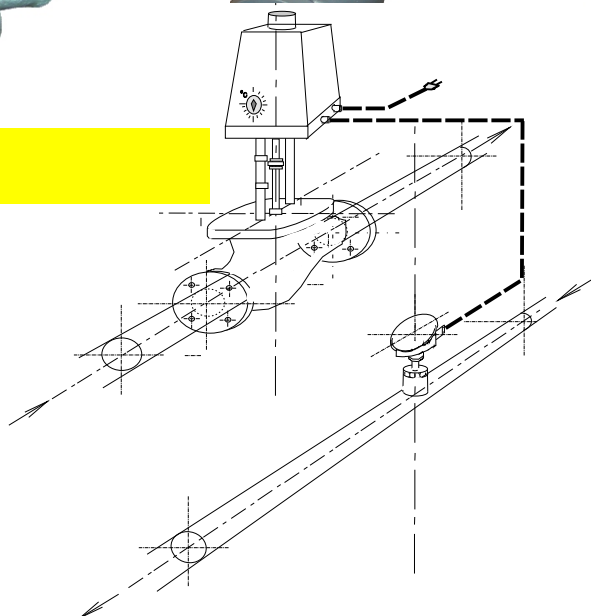

5/1

ELEKTROMEHANIČKI SERVOPOGONI ISOMACT I MODACT



	ISOMACT STO	ISOMACT STO1	ISOMACT ST2	MODACT MT 52.400	MODACT MO 52.000
Max sila	4000 N	6300 N	21500 N	28.800 N	
Max moment					120 Nm
Brzina	4-40 mm/min	10-63 mm/min	10 120 mm/min	32 180 mm/min	10 63 min
max.hod.	40 mm	50 mm	80 mm	100 mm	100 mm
Snaga motora	2,75 W	15 W	90 W	120 370 W	120 370 W
Napajanje	230V, 50Hz	230V, 50Hz	230V, 50Hz	3 x 380V AC	3 x 380V AC
Doz. temp. okoline	-25 +55 C	-25 +55 C	-25 +55 C	-25 +55 C	-25 +55 C
Zaštita	IP 54	IP 65	IP 65	IP 55	IP 55
Šema spajanja	Z20+Z21+Z22	Z33+Z21+Z22	Z1a+Z11a+Z5a	Z279a+Z298+Z5a	Z279a+Z298+Z5a
Težina	2,5 4,5 kg	5,4 8 kg	17 21 kg	25 30 kg	26,5 29,5 kg

šeme povezivanja

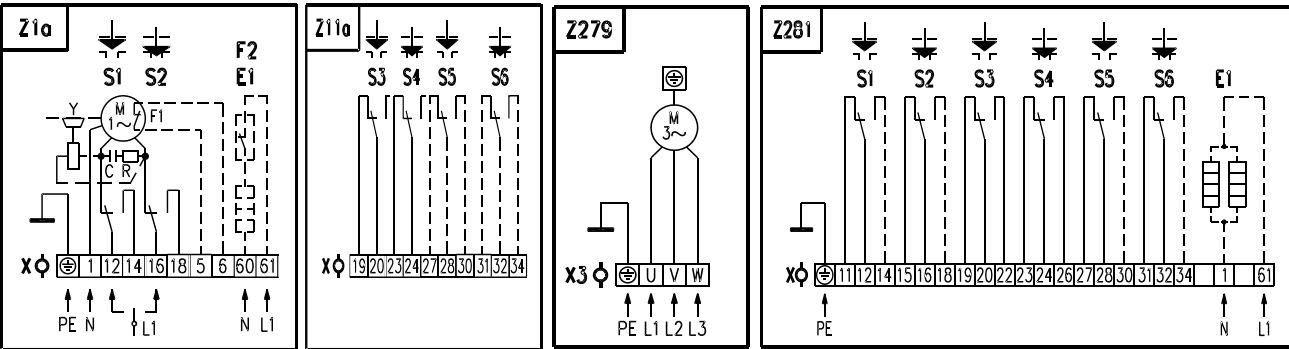
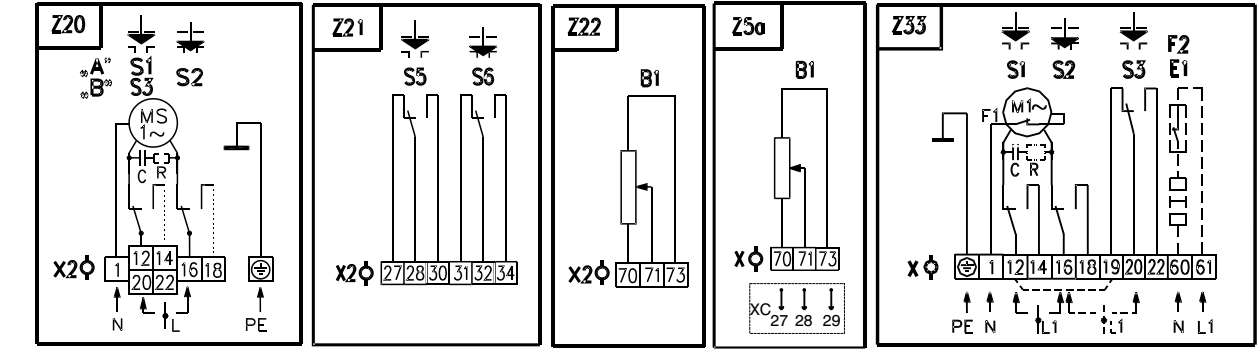

LEGENDA:

- B1 Otporni davač položaja
- C Kondenzator
- E1 Grejač
- F2 Termostat
- M1(MS) Elektromotor
- R Otpornik
- S1 Moment prekidač "otvoreno"
- S2 Moment prekidač "zatvoreno"
- S3 Prekidač hoda "otvoreno"
- S5 Dodatni prekidač hoda "otvoreno"
- S6 Dodatni prekidač hoda "zatvoreno"

5